

SOLUTION OF WORLDWIDE SALES NETWORK

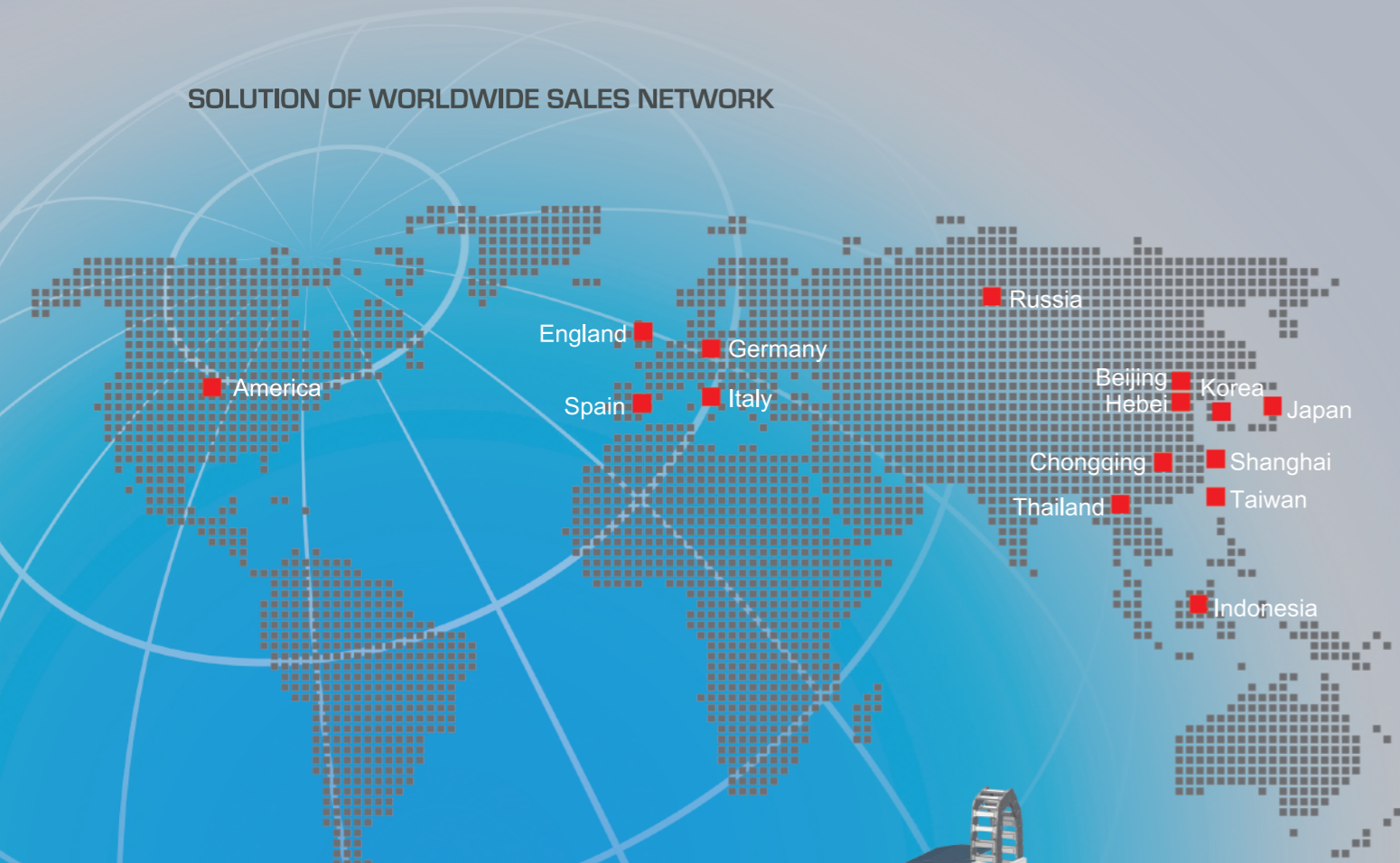

TWISTER

SERIES 

Moving Gantry Type 5-axis Machining Center

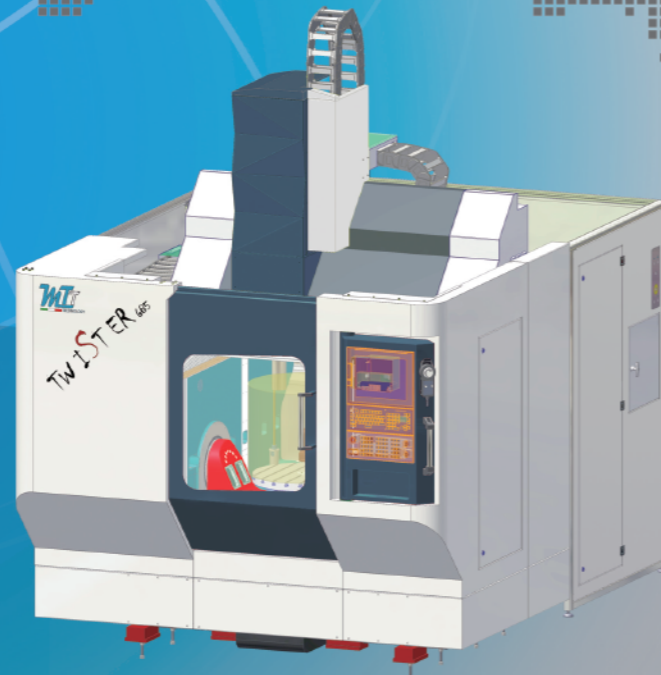

Twinhorn

CHI-FA MACHINERY MANUFACTURER CO., LTD.

No. 44-8, MING-CHUNG RD., SHENG-KANG DIST.,
TAICHUNG CITY, TAIWAN 42948
Tel: +886-4-2562-8747 (Rep.)
Fax: +886-4-2561-4199
E-mail: inquiry@twinhorn.com.tw

www.twinhorn.com



Design 201902.TWISTER (E1)600P

TWISTER

New generation 5-ax high efficiency machine tool

- All 3 linear axes are located on top, dynamic performance independent of table loading.
- X & Y axes are directly coupled with servo motors while Y-axis is driven by dual ballscrews, which ensures the precise linear movements with high acceleration and rapid feed.
- X/Y/Z axes are equipped with cross-roller linear guides, and optical scales.
- A & C tilting/rotary axes are equipped with Renishaw high res. rotary optical encoders.
- Built-in spindle is an essential part of excellence.

Y-

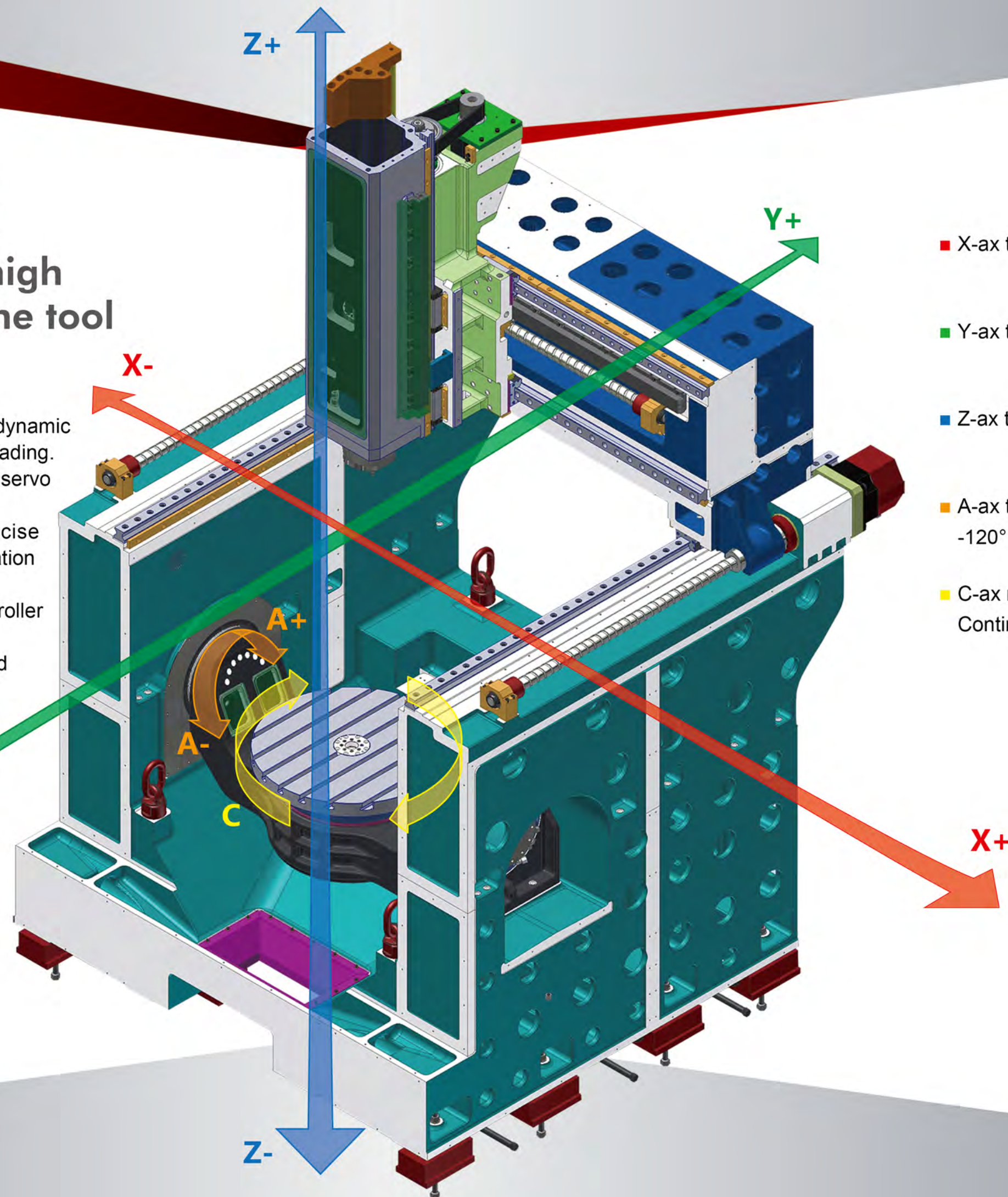

■ X-ax travel: 650 mm

■ Y-ax travel: 820 mm

■ Z-ax travel: 550 mm

■ A-ax tilting angle range:
-120° ~ +100°

■ C-ax rotary angle range:
Continuous

X+

High Precision Transmission System

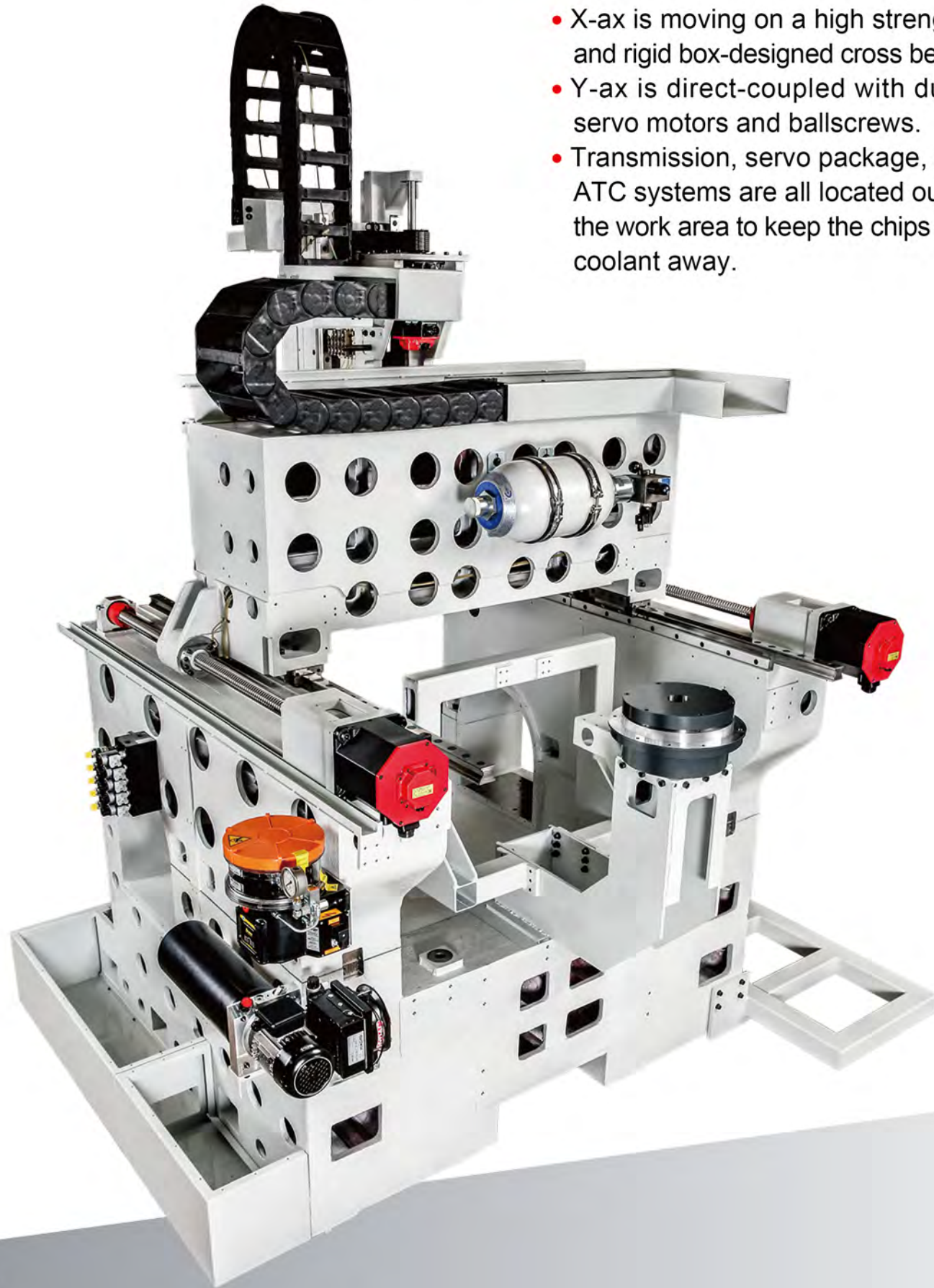

- X-ax is moving on a high strength and rigid box-designed cross beam.
- Y-ax is direct-coupled with dual servo motors and ballscrews.
- Transmission, servo package, and ATC systems are all located out of the work area to keep the chips and coolant away.

High Rigidity Structure Design

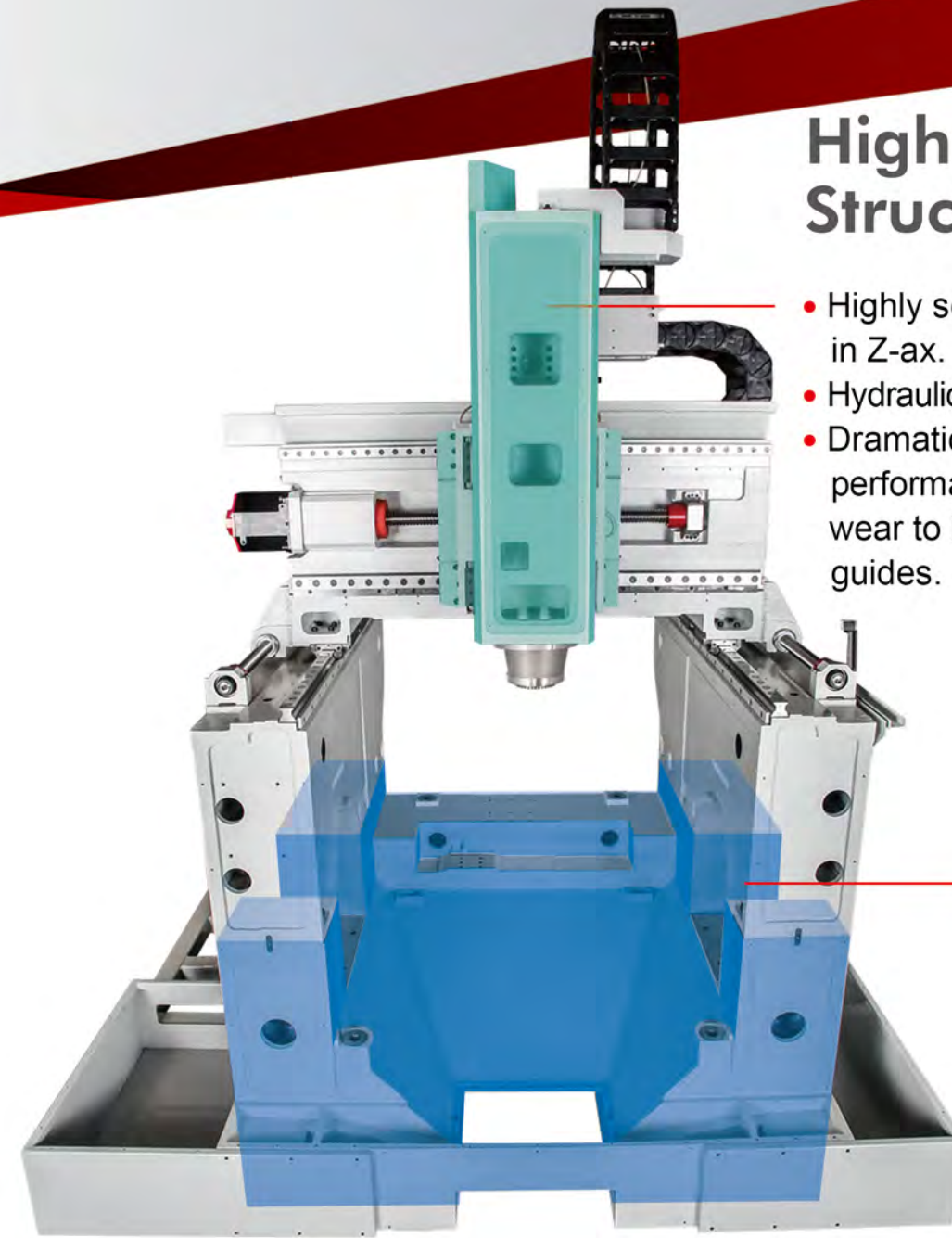

- Highly sensitive ram movement in Z-ax.
- Hydraulic counter balance system.
- Dramatically enhance the dynamic performance and minimize the wear to ballscrew and linear guides.

- High rigidity base structure ensures optimized vibration suppression.

- Chips can be easily evacuated through a port located right underneath the table.

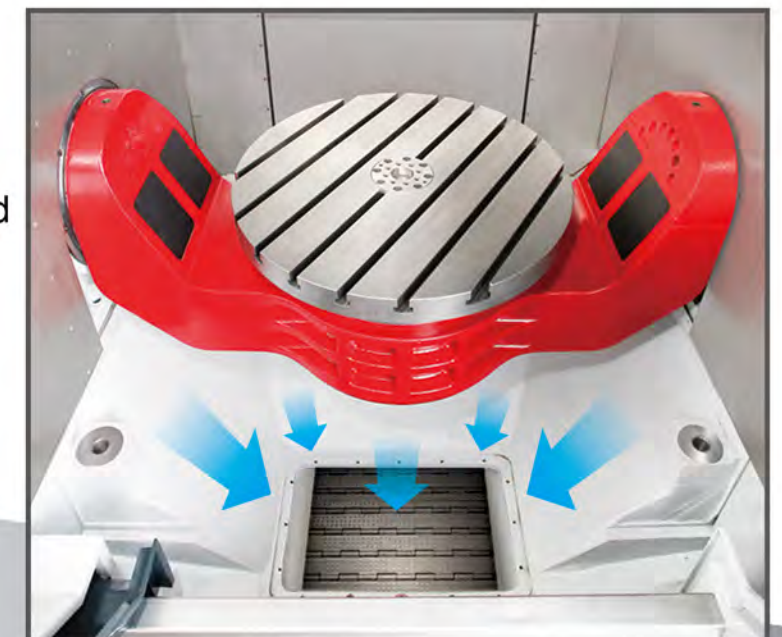

High Performance 5-Axis Machining Center

Ergonomical Working Area Design



- Twister series model features U-shaped base, and equipped with dual-supported A/C tilting & rotary table, high speed built-in spindle, cross-roller type linear guides, and precise optical scales.
- Precise angular compensation and RTCP (Rotated Tool Center Point) functions are available (optional), to ensure the best accuracy of tool tip path during complex and irregular curved surface machining tasks.

- Machine top is fully covered by finned crankcase type way cover.
- Fully closed working environment is achieved while the way cover closes.



- Fixture and workpieces can be easily hoisted onto the table with a crane while the roof cover is opened.
- The working area is covered with stainless steel sheets to keep it clean and elegant.



- Large touch screen and keyboard provides the best operating experience to the operators.
- Fanuc iHMI Function is available (Optional) for more innovative possibilities.

Tool magazine & ATC System

- Twister features a proprietary tool magazine to minimize the machine footprint while maximizing the working area.
- Standard: Carousel type 30T (Option: T-shaped chain type 40T / 60T).
- ATC and tool magazine are installed behind the machining area to keep the chip and dust away.
- Servo-driven tool magazine facilitates fastest tool selection and shortest tool waiting time.
- Servo-driven ATC system achieves optimized tool change time 2 secs. (Tool to Tool).

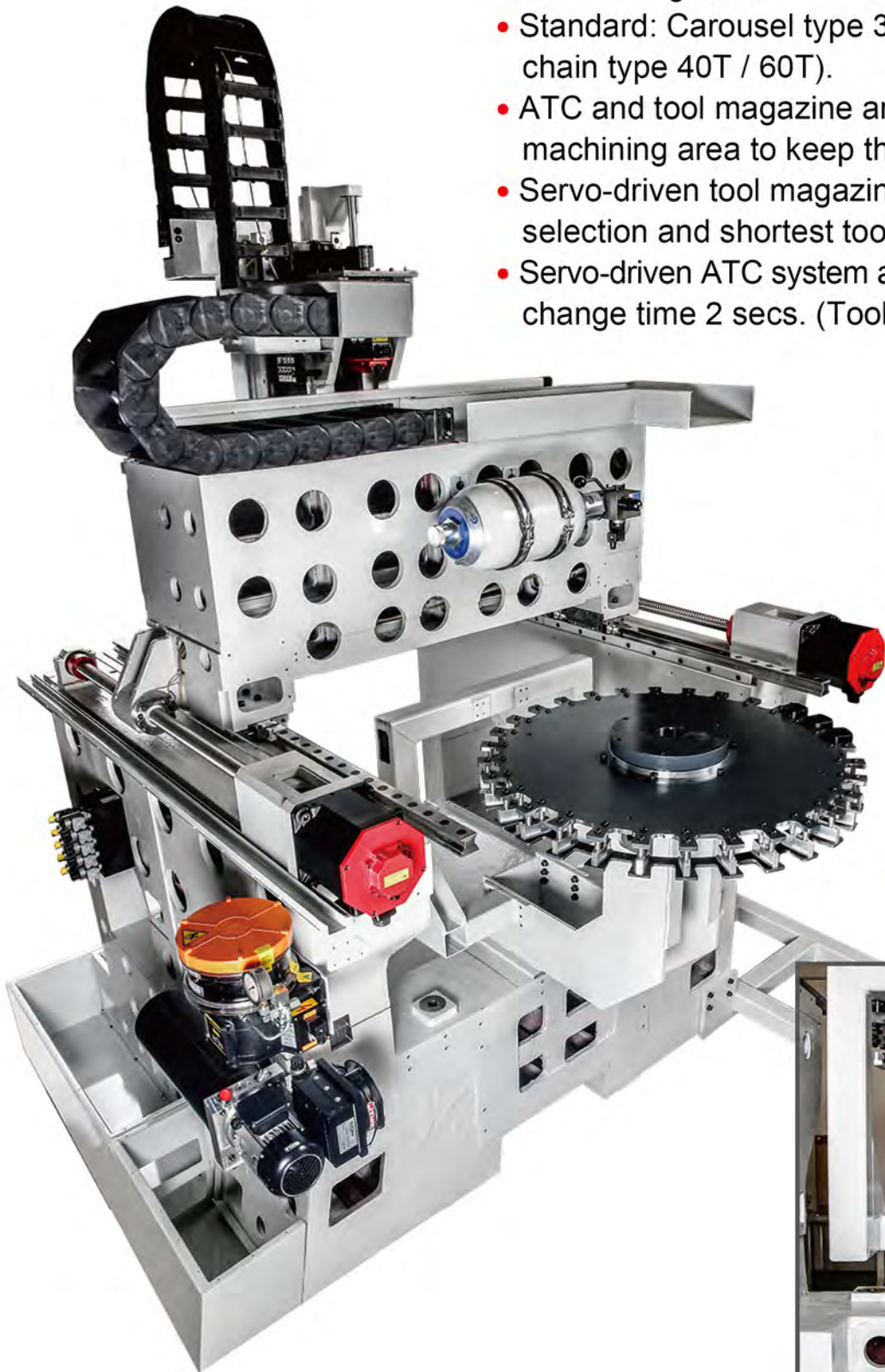

• Carousel type 30T



High Performance Built-in Spindle



• Outstanding 5-axis simultaneous controlled milling performance.

Spindle Power / Torque Diagram



- Powerful built in spindle.
- PM (Permanent Magnetic) design built-in motor features minimum vibration, lowest base speed, and great power output.

Spindle speed	Built-in Spindle 12000 rpm opt. 15000 rpm / 20000 rpm
Spindel taper	BBT40 (opt. HSK A63)

FANUC	
Spindle motor	11 / 18.5 kW : 45.7 / 124 N·m (S1/S3-10%, LOW) 15 / 26 kW : 23.9 / 41.4 N·m (S1/S3-25%, HIGH)
MITSUBISHI	
Spindle motor	7.5 / 11 kW : 31.1 / 80.8 N·m (S1/S3-10%, LOW) 11 / 18.5 kW : 17.5 / 29.4 N·m (S1/S2-10min, HIGH)
SANGALLI	
Spindle motor	24 / 32 kW : 58 / 80 N·m (S1/S6-40%)

A/C axes Tilting Rotary Table

- A-ax is powered by a high precision gear reducer, and equipped with dual hydraulic clamping system.
- C-ax is driven by a torque motor, and clamped by hydraulic disc brake system.
- Both A & C axes adopt large diameter bearings to ensure durable service life and fabulous rigidity.
- Table loading 750 Kgs.
- 4 hydraulic/pneumatic paths for the integration of automatic fixtures and jigs.



- Large table diameter makes the installation of workpiece or automatic fixture easier than ever.



AxiSet™
Check-Up(opt.)



A/C axes Tilting Rotary Table

Swing range (3D illustration)

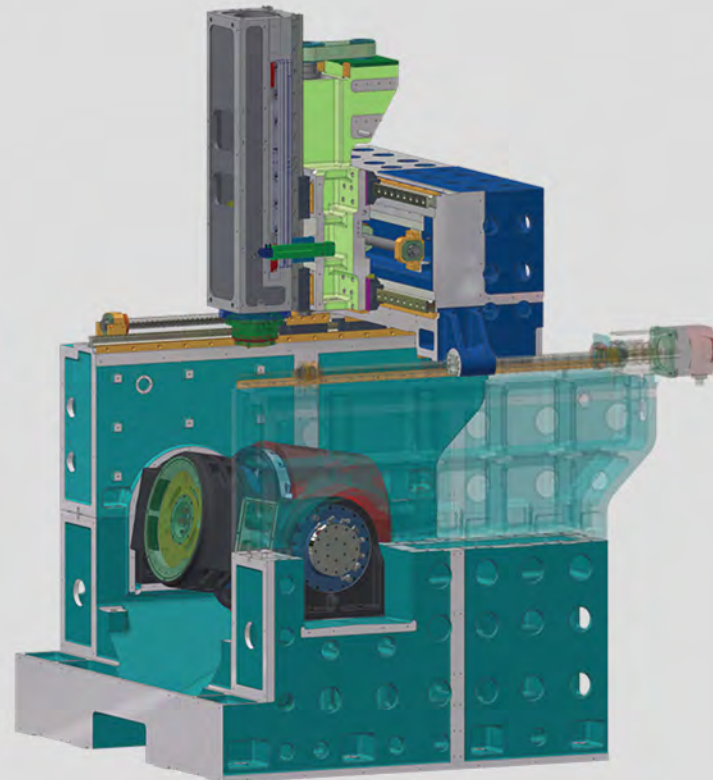
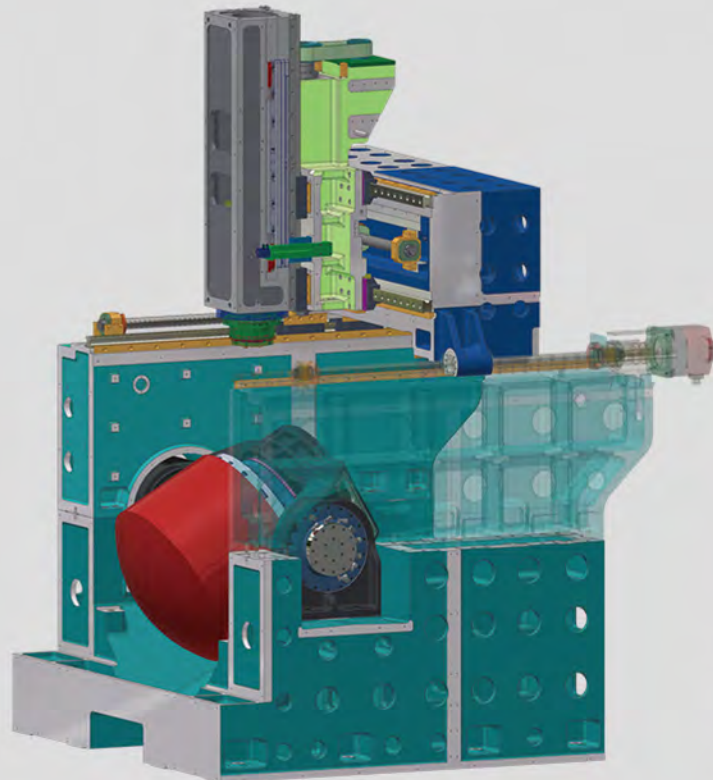
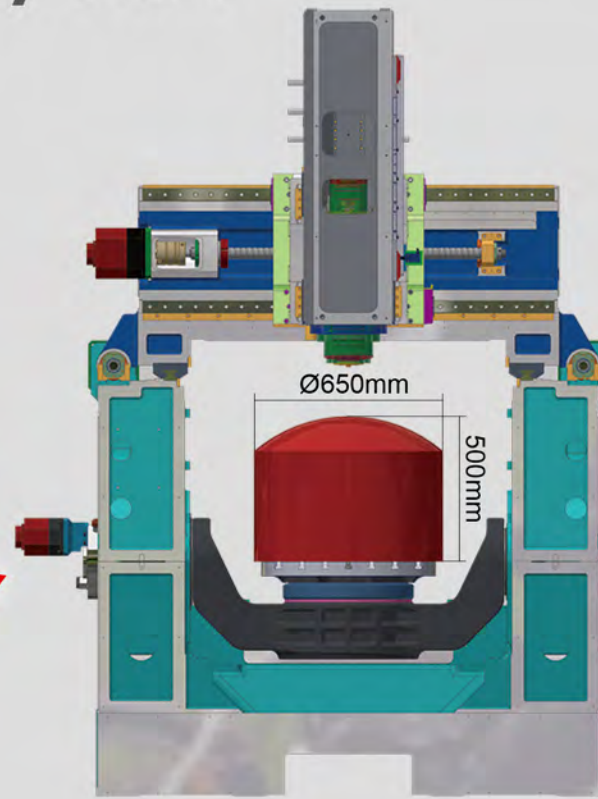

Sample Parts

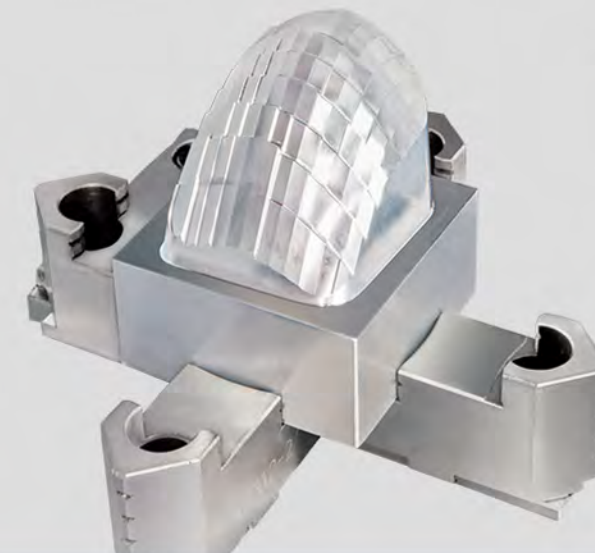
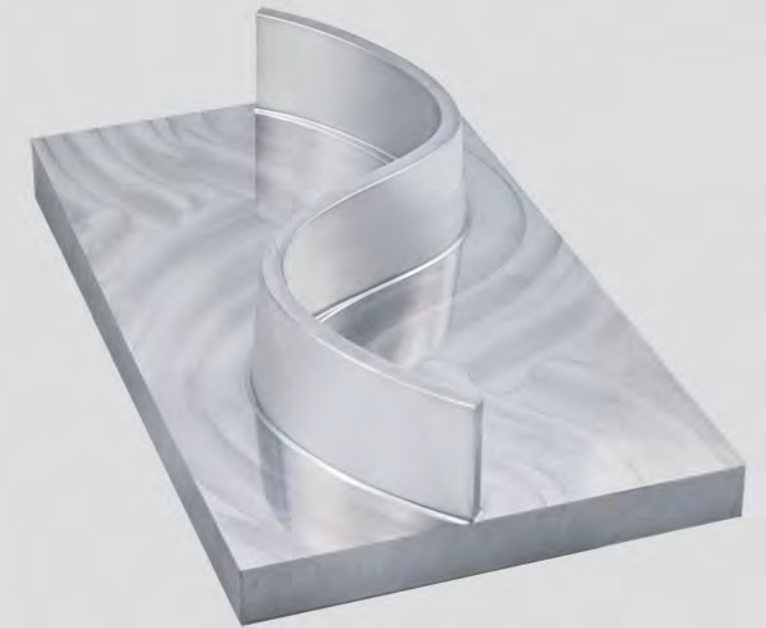

3-ax Interference Drawing

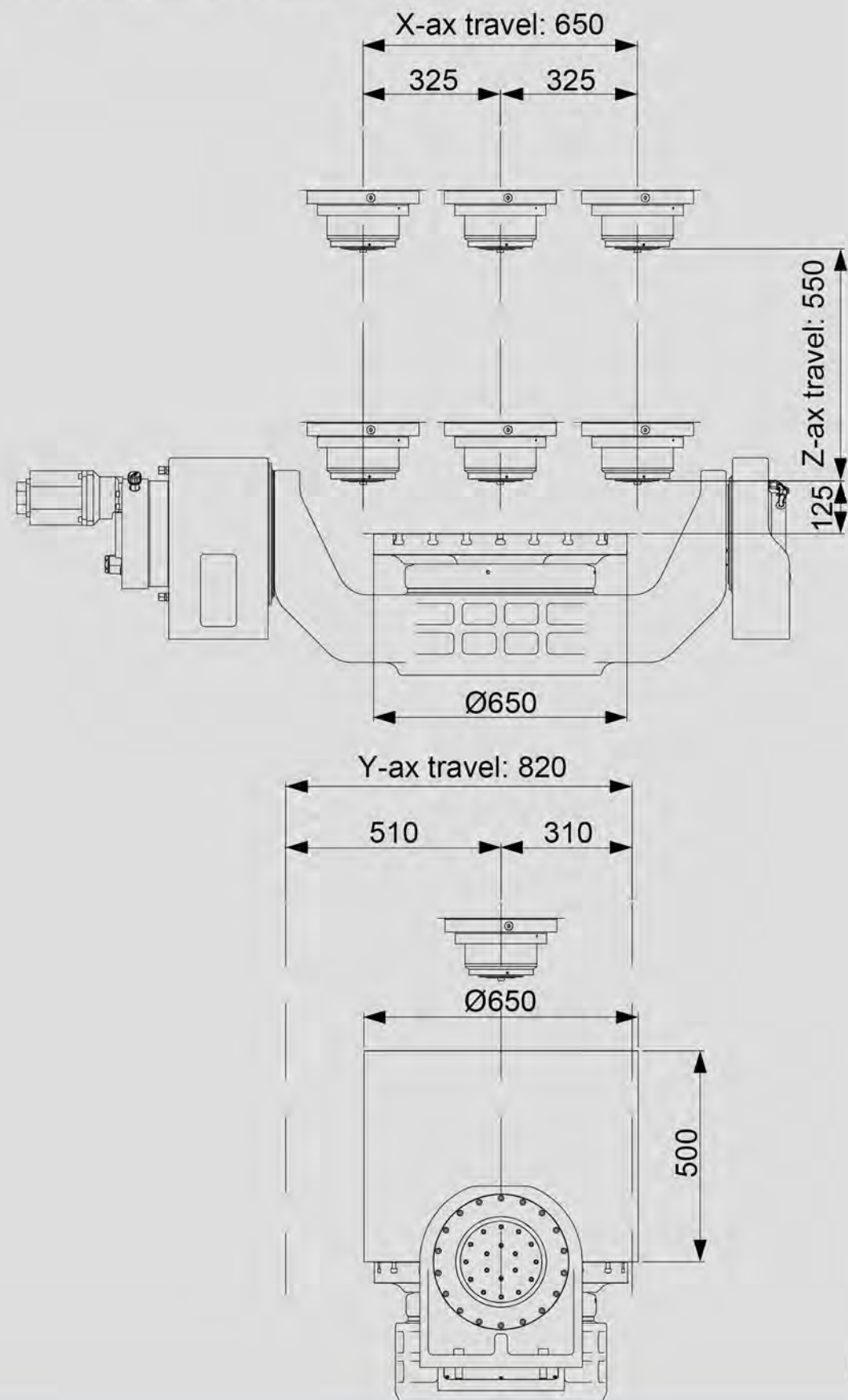

Unit:mm

A-ax Tilting Interference Drawing

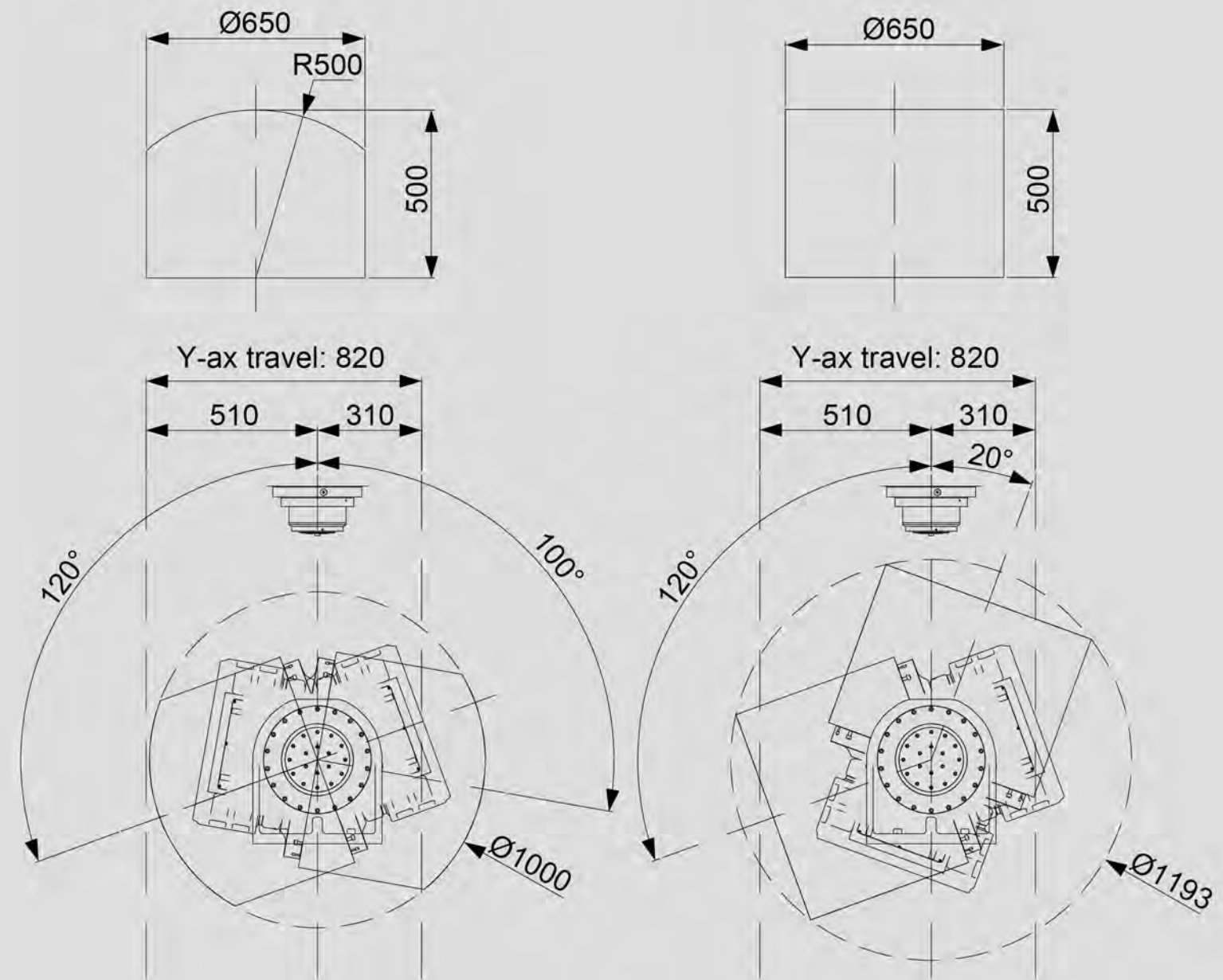

Unit:mm

Outline Dimension Drawing

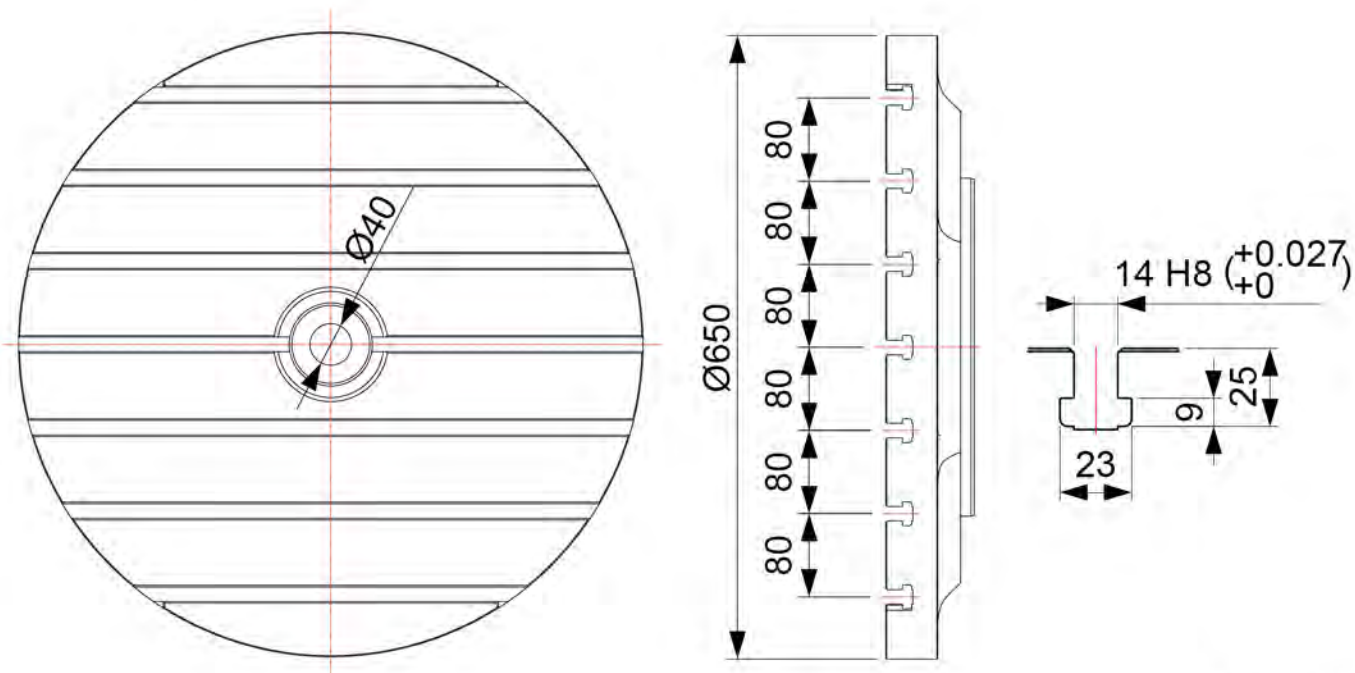
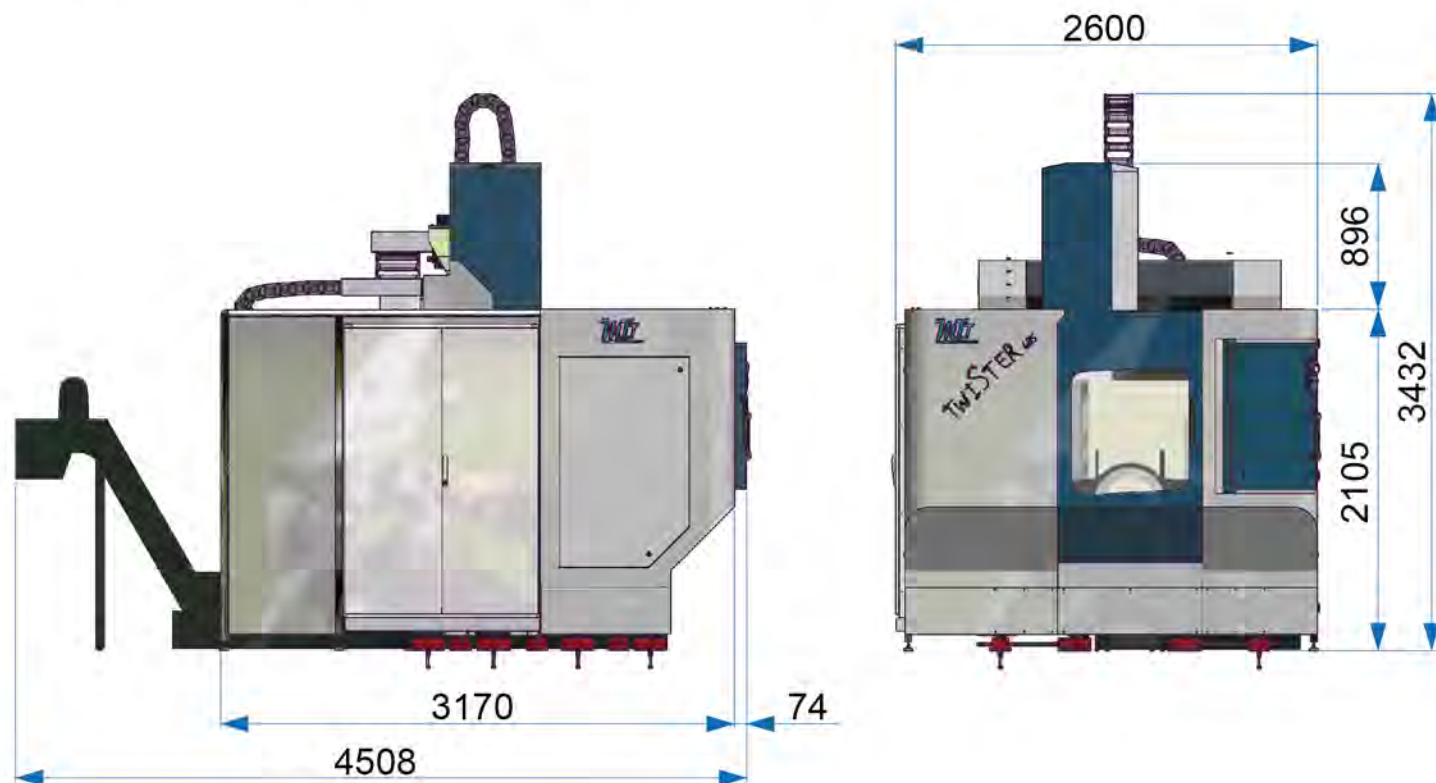

Unit:mm

Machine Specification

TRAVEL	
X-ax travel	650 mm
Y-ax travel	820 mm
Z-ax travel	550 mm
Spindle nose to pallet surface	125 ~ 675 mm
Axis movement "A" tilting	-120°~ +100°
Axis movement "C" Table	0°~360°
PALLET	
Table size	$\text{Ø} 650$
Height of the table surface from the floor	910 mm
Number of slots	7
Distance between T-slots	80 mm
Maximum loading capacity	750 kg
SPINDLE	
Spindle speed	Built-in 12000 rpm
Spindle motor	(F): 11 / 18.5 kW (S1/S3-10%, LOW) 15 / 26 kW (S1/S3-25%, HIGH)
Spindle rated torque	(F): 45.7 / 124 N·m (S1/S3-15%, LOW) 23.9 / 41.4 N·m (S1/S3-25%, HIGH)
Spindle taper	BBT40 (opt. HSK- A63)
FEED	
Rapid feed (X / Y / Z axis)	36 m/min (opt. 48 m/min , 60 m/min)
Cutting feed (X / Y / Z axis)	10,000 mm/min
Ballscrew dia.	40 mm
Axis rotation speed "A"	5 rpm
Axis rotation speed "C"	300 rpm
AUTOMATIC TOOL CHANGER (ATC)	
Tool change system	ARM
Type of tool shank	BBT40 (opt. HSK- A63)
Type of pull-stud	MAS403 B40T-1
Tool exchange time	T-T 2 sec ; C-C 4 sec
Max. tool dia. (adjacent pot full / empty)	$\text{Ø} 80 / 120$ mm
Max. tool length	300 mm
Max. tool weight	7 kg
SUPPLY	
Electric voltage	200-220 V (50 / 60 Hz)
Electric power supply	40 KVA
Air pressure & volume	0.6 MPa , 350 liters / min
Coolant tank	400 L
SIZE	
Floor space	4508×2600 mm
Machine height	3500 mm
Machine weight	10000 Kg

* The company reserves the right to change the mechanical specifications, accessories and appearance without prior notice.

Standard Accessories

- Built-in spindle 12000 rpm
- Arm type tool magazine 30 tools
- Coolant system
- Fully enclosed splash guard
- LED lamp
- Automatic lubrication system
- Operation indication lamp
- Three-axis linear scale
- A / C axis rotary optical encoders
- Spindle air curtain
- Chip conveyor and cart
- Spindle oil cooler
- Heat exchanger for electrical cabinet
- Leveling bolts and pads
- Tools and tool box
- Operation and maintenance manual
- Water gun and air gun

Optional Accessories

- Built-in spindle 15000 rpm / 20000 rpm
- Coolant though spindle system (20 bar)
- Arm type tool magazine 40 tools, 60 tools
- Automatic tool length measurement
- Automatic work piece measurement
- Five-axis rotary center error compensation function (RTCP)
- Transformer
- Controller:
Fanuc
Mitsubishi
Siemens
Heidenhain
Fagor